



SHUNTS, CURRENT SHUNTS, AND CURRENT-SENSING RESISTORS

Resistive Products



TABLE OF CONTENTS

- Introduction 2
- Shunt 2
- Current Shunt 3
- Current Sensor 3
- Shunts/Current Sensors**
- Chips and SMD 4
- Exposed Element 5
- Shunts, Low-Ohm**
- High Power (100 W to 1000 W) 6
- Mid Power (10 W to 100 W) 7
- Low Power (1 W to 10 W) 7
- Current Sensors, Lower-Ohm**
- Axial Leads 8
- Radial Leads 9
- Axial/Radial Leads 9
- Characteristics and Design Considerations**
- Kelvin Connection 10
- Tolerance and Measurement of Resistance at Low Values 10
- Power Rating and Thermal Dissipation 11
- One Short Pulse 12
- Equally Spaced Repetitive Pulses 12
- Long Pulses (100 milliseconds to 5 seconds) 12
- Current Rating 12
- Reactance, Impedance 13
- Thermal EMF 13
- Noise 14
- Temperature Coefficient of Resistance (TCR) 15
- Design Factors**
- Shunts 16
- Sensors 16
- Typical Applications 16

RESOURCES

- For technical questions contact ww2bresistors@vishay.com
- Sales Contacts: <http://www.vishay.com/doc?99914>

One of the World's Largest Manufacturers of
Discrete Semiconductors and Passive Components





Introduction

Generally speaking, there is considerable overlapping in the use of the terms “shunts,” “current shunts,” and “current sensors.” Although these three terms are used interchangeably, there are some subtle differences that are worth noting and that may suggest a preference for one or another term as it relates to a particular application.

Shunt

A shunt is a resistive device employed to divert most of the current in an electric circuit. The earliest shunts were meter shunts used as external accessories to ammeters allowing one meter to be used for a variety of current levels depending upon which shunt was chosen. These were often massive four-terminal devices with the smaller potential terminals connected to the meter and the larger current terminals connected to the circuit under test. Present day ammeters are more likely to be specific to a particular current range – one meter, one internal shunt. These internal shunts are resistors with current connections to the external terminals of the ammeter and voltage connections made internally to the meter movement.

In addition to these measurement shunts, power shunts used for electric motor starting, braking, and speed control. Loading, neutral grounding, preheating and capacitor unloading are all applications in which a resistor is called upon to shunt large amounts of current.

For purposes of this brochure a shunt shall be any two- or four-terminal resistor of sub-ohmic resistance value and high-current capacity. To fully describe a particular shunt, the following characteristics may require identification:

Mechanical (as applicable)

- All external dimensions
- Body material and finish
- Terminal material and finish
- Mounting method and hardware
- Maximum internal hot-spot temperature
- Maximum case temperature and test location (related to hot-spot temperature)
- External conductors, termination, and method of attachment
- External heat sink capacity and mounting method
- Cooling water connection with specified inlet temperature, flow rate, and pressure
- Part number and part marking
- Unit packaging method and package marking
- Unit weight and shipping weight

Electrical (as applicable)

- Resistance value and tolerance (for 4-terminal devices, also the maximum resistance value between the current terminals)
- Maximum current rating
- Maximum continuous-duty wattage rating based on specified heat sinking method
- Maximum pulse power under specified conditions
- Maximum temperature coefficient of resistance and temperature range and reference
- Maximum reactance
- Maximum dielectric withstanding voltage to mounting hardware



Current Shunt

For the purpose of this brochure a current shunt is defined as a shunt capable of current sensing as well as conducting significant current.

Current Sensor

A current sensor is a resistive device employed to sense levels of current. Current sensors are used in applications where the emphasis is on accuracy and repeatability under all conditions and less on high-current capability. Applications such as force-balance scales, E beam deflection systems, switching power supplies, all rely on current sensors to feed back and control the current. For the purpose of this brochure, a current sensor is defined as a four-terminal resistor of high accuracy and stability and usually of low resistance value. To fully describe a particular current sensor, the following characteristics must be identified:

Mechanical (as applicable)

- All external dimensions
- Body material and finish
- Lead material and finish
- Identification of current and potential leads
- Part number and part marking
- Unit packaging method and package marking
- Unit weight and shipping weight

Electrical (as applicable)

- Resistance value and tolerance
- Alternate specification: voltage output and tolerance for a given current throughput, e.g. 50 mV \pm 0.1 % per A
- Maximum temperature coefficient of resistance
- Maximum wattage rating
- Maximum reactance
- Maximum dielectric withstanding voltage
- Maximum current noise
- Maximum thermal EMF at the terminals



SHUNTS, CURRENT SHUNTS, AND CURRENT-SENSING RESISTORS

Resistive Products

Shunts/Current Sensors: Chips and SMD

These low-ohm chip resistors are examples of the range of capabilities available. Hybrid packaging and surface-mounting practitioners will find these leadless devices to be useful solutions for current sensing in small spaces.

Brand	Product Image	Part Number	Sizes Available	Length (inch / [mm])	Power Rating (W)	Resistance Range, Tolerance, and Other Features
Vishay Dale		WSL WSLP WSLT	0603, 0805, 1206, 2010, 2512, 2816, 3921, 5931	0.06 to 0.59 [1.52 to 15]	0.1 to 5	<ul style="list-style-type: none"> 0.0003 Ω to 0.5 Ω $\pm 1\%$ Power Metal Strip®
		WSH WSHM	2818	0.280 [7.1]	5	<ul style="list-style-type: none"> 0.001 Ω to 0.100 Ω $\pm 1\%$ Improved thermal management Power Metal Strip
		WSR	4527	0.455 [11.56]	2 to 5	<ul style="list-style-type: none"> 0.001 Ω to 1 Ω $\pm 1\%$ Molded Power Metal Strip
		WSL2726 WSLP2726 WSLT2726	2726	0.272 [6.9]	3 to 7	<ul style="list-style-type: none"> 0.0003 Ω to 0.005 Ω $\pm 1\%$ 4-terminal Power Metal Strip
		WSL4026 WSLP4026 WSLT4026	4026	0.400 [10.1]	3 to 7	<ul style="list-style-type: none"> 0.0003 Ω to 0.005 Ω $\pm 1\%$ 4-terminal Power Metal Strip
		WSL3921 WSLP3921 WSLT3921	3921	0.394 [10]	3 to 9	<ul style="list-style-type: none"> 0.0002 Ω to 0.004 Ω $\pm 1\%$, $\pm 5\%$ Power Metal Strip
		WSL5931 WSLP5931 WSLT5931	5931	0.591 [15]	5 to 10	<ul style="list-style-type: none"> 0.0002 Ω to 0.004 Ω $\pm 1\%$, $\pm 5\%$ Power Metal Strip
		WSL3637	3637	0.36 [9.14]	3	<ul style="list-style-type: none"> 0.001 Ω to 0.01 Ω 1% 4-terminal Power Metal Strip
		WSK	0612 2512	0.06 to 0.25 [1.50 to 6.35]	1	<ul style="list-style-type: none"> 0.0005 Ω to 0.025 Ω $\pm 1\%$ 4-terminal Power Metal Strip
		WSC	2012, 2515, 4527, 6927	0.2 to 0.69 [5.08 to 17.52]	0.5 to 3	<ul style="list-style-type: none"> 0.1 Ω to 8 kΩ $\pm 1\%$ Molded wirewound
Vishay Sfernice		MSP	2715, 4528, 5828	0.27 to 0.58 [6.9 to 14.8]	1 to 2.5	<ul style="list-style-type: none"> 0.05 Ω to 15 kΩ $\pm 1\%$ Molded wirewound



SHUNTS, CURRENT SHUNTS, AND CURRENT-SENSING RESISTORS

Resistive Products

Shunts/Current Sensors: Exposed-Element

These exposed-element devices are examples of the range of capabilities available. Exposed-element devices represent a cost-effective approach to current sensing.

Brand	Product Image	Part Number	Sizes Available	Length (inch / [mm])	Power Rating (W)	Resistance Range, Tolerance, and Other Features
Vishay Dale		SPR-889	1 size	2.4 [61]	13	<ul style="list-style-type: none"> • 0.0001 Ω to 0.00025 Ω • $\pm 1\%$ • 4-terminal • Buss block terminals
		SPR-2166	1 size	2.75 [70]	13	<ul style="list-style-type: none"> • 0.0004 Ω to 0.002 Ω • $\pm 1\%$ • 4-terminal
		SPR-2039	1 size	1.05 [26.7]	3.5	<ul style="list-style-type: none"> • 0.0035 Ω to 0.025 Ω • $\pm 1\%$ • 4-terminal PCB mount
		SPR-2093	1 size	1.4 [35.6]	13	<ul style="list-style-type: none"> • 0.0004 Ω to 0.002 Ω • $\pm 1\%$ • 4-terminal PCB mount
		SPR-676	1 size	0.74 [18.8]	0.75 to 1	<ul style="list-style-type: none"> • 0.015 Ω to 0.265 Ω • $\pm 0.5\%$ • 4-terminal PCB mount
		SPU-104	1 size	0.5 [12.7]	1.875	<ul style="list-style-type: none"> • 0.0025 Ω to 0.01 Ω • $\pm 0.1\%$ • 4-terminal PCB mount
		SPU-111-1	1 size	0.35 [8.9]	1	<ul style="list-style-type: none"> • 0.005 Ω • $\pm 0.1\%$ • 4-terminal PCB mount
		SPU-114	1 size	1.1 [27.9]	1	<ul style="list-style-type: none"> • 0.0016 Ω to 0.02 Ω • $\pm 0.1\%$ • 4-terminal PCB mount
		WSBS8518	8518	3.346 [85]	36	<ul style="list-style-type: none"> • 50 $\mu\Omega$ to 1000 $\mu\Omega$ • $\pm 1\%$, $\pm 5\%$ • Battery shunt
		WSBM8518	8518	3.346 [85]	36	<ul style="list-style-type: none"> • 100 $\mu\Omega$ • $\pm 1\%$, $\pm 5\%$ • Battery shunt with molded enclosure
		WSMS5515	5515	2.165 [55]	3	<ul style="list-style-type: none"> • 50 $\mu\Omega$ to 1000 $\mu\Omega$ • $\pm 1\%$, $\pm 5\%$ • Meter shunt
		WSMS2908	2908	1.142 [29]	3	<ul style="list-style-type: none"> • 300 $\mu\Omega$ to 660 $\mu\Omega$ • $\pm 1\%$, $\pm 5\%$ • Meter shunt
		WSMS2906	2906	1.142 [29]	3	<ul style="list-style-type: none"> • 300 $\mu\Omega$ to 660 $\mu\Omega$ • $\pm 1\%$, $\pm 5\%$ • Meter shunt
		WSMS3124	3124	1.195 [30.35]	3	<ul style="list-style-type: none"> • 100 $\mu\Omega$ to 750 $\mu\Omega$ • $\pm 1\%$, $\pm 5\%$ • Meter shunt









SHUNTS, CURRENT SHUNTS, AND CURRENT-SENSING RESISTORS

Resistive Products

Shunts, Low Ohm: High-Power (100 W to 1000 W)

These high-power devices are examples of the range of capabilities available.

Brand	Product Image	Part Number	Sizes Available	Length (inch / [mm])	Power Rating (W)	Resistance Range, Tolerance, and Other Features
Vishay Dale		HLZ	12 sizes	2 to 10.5 [50.8 to 266.7]	35 to 375	<ul style="list-style-type: none"> • 0.05 Ω to 32 Ω • $\pm 10\%$ • 375 $^{\circ}\text{C}$ max hot spot • Air-cooled
		SPR-761	1 size	3.5 [89]	100	<ul style="list-style-type: none"> • 0.005 Ω to 0.01 Ω • $\pm 1\%$ • Chassis mount
		SPR-1002	1 size	4.5 [114]	450	<ul style="list-style-type: none"> • 0.05 Ω to 37.5 kΩ • $\pm 1\%$ • Liquid-cooled
		SPR-1009	1 size	4.5 [114]	250	<ul style="list-style-type: none"> • 0.003 Ω • 4-terminal • Chassis mount
Vishay Sfernice		RSO	4 sizes	5.43 to 14.69 [138 to 373]	160 to 1000	<ul style="list-style-type: none"> • 0.068 Ω • 450 $^{\circ}\text{C}$ temperature rise
		RPS	2 sizes	2.87 [73]	250 and 500	<ul style="list-style-type: none"> • 0.24 Ω to 1 MΩ • $\pm 1\%$ • Heat sink mounting
		RTOP	2 sizes	1.5 [38]	100 to 200	<ul style="list-style-type: none"> • 0.046 Ω to 1 MΩ • $\pm 1\%$ • Multiple resistors in single package • Heat sink mounting





SHUNTS, CURRENT SHUNTS, AND CURRENT-SENSING RESISTORS

Resistive Products



Shunts, Low Ohm: Mid-Power (10 W - 100 W)

These mid-power devices are examples of the range of capabilities available. Some of these shunts are suitable for precise current sensing and should be considered when a power requirement exists in addition to the precision and stability requirements of current sensing.

Brand	Product Image	Part Number	Sizes Available	Length (inch / [mm])	Power Rating (W)	Resistance Range, Tolerance, and Other Features
Vishay Dale		SPR-390	1 size	2.5 [64]	50	<ul style="list-style-type: none"> • 0.001 Ω to 0.01 Ω • $\pm 1\%$ • Chassis mount
		SPR-439	1 size	1.5 [38]	25	<ul style="list-style-type: none"> • 0.001 Ω to 0.01 Ω • $\pm 1\%$ • Insulated flexible leads

Shunts, Low Ohm: Low-Power (1 W - 10 W)

These low-power devices are examples of the range of capabilities available. Good practice calls for derating with tolerance to hold the time drift to a level consistent with the initial tolerance.

Brand	Product Image	Part Number	Sizes Available	Length (inch / [mm])	Power Rating (W)	Resistance Range, Tolerance, and Other Features
Vishay Dale		SPR-383	1 size	1.0 [25]	5	<ul style="list-style-type: none"> • 0.0015 Ω to 0.01 Ω • $\pm 1\%$ • Special aluminum housing • Flexible leads
		LVR-1/3/5/10	4 sizes	0.437 to 1.828 [11 to 46.4]	1/3/5/10	<ul style="list-style-type: none"> • 0.005 Ω to 0.8 Ω • $\pm 1\%$ • Molded axial leads



SHUNTS, CURRENT SHUNTS, AND CURRENT-SENSING RESISTORS

Resistive Products

Current Sensors, Lower-Ohm: Axial Leads

These current sensors with axial leads are examples of the range of capabilities available. Some of these current sensors are plastic-encapsulated while others are in metal housings. Metal enclosures provide a more rugged mounting and more thermal conduction.

Brand	Product Image	Part Number	Sizes Available	Length (inch / [mm])	Power Rating (W)	Features Resistance Range, Tolerance, and Other Features
Vishay Dale		SPR-1005	1 size	0.975 [24.8]	5	<ul style="list-style-type: none"> • 0.008 Ω to 0.5 Ω • $\pm 1\%$ • 4-terminal molded
		SPR-2013	1 size	0.8 [20]	2	<ul style="list-style-type: none"> • 0.0025 Ω to 0.3 Ω • $\pm 0.1\%$ min • 4-terminal molded
		SPU50/51/52/53	4 sizes	0.66 to 1.87 [16.8 to 47.5]	1/2/4/5	<ul style="list-style-type: none"> • 0.001 Ω to 0.5 Ω • $\pm 1\%$ • 4-terminal molded
		SPR-2073	1 size	0.875 [22.2]	3	<ul style="list-style-type: none"> • 0.001 Ω to 0.25 Ω • $\pm 1\%$ • 4-terminal • Ceramic case
		SPR-2123	1 size	0.875 [22.2]	5	<ul style="list-style-type: none"> • 0.001 Ω to 0.25 Ω • $\pm 1\%$ • 4-terminal • Ceramic case
		SPR-2091	1 size	1.88 [40]	10	<ul style="list-style-type: none"> • 0.001 Ω to 0.25 Ω • $\pm 1\%$ • 4-terminal • Ceramic case
		RH-10-65	1 size	0.75 [19]	10	<ul style="list-style-type: none"> • 0.001 Ω to 6.55 kΩ • $\pm 1\%$ • 4-terminal • Aluminum-housed chassis mount
		RH-25-137	1 size	1.062 [27]	25	<ul style="list-style-type: none"> • 0.001 Ω to 13.4 kΩ • $\pm 1\%$ • 4-terminal • Aluminum-housed chassis mount
		RH-50-10	1 size	1.97 [50]	50	<ul style="list-style-type: none"> • 0.001 Ω to 39.2 kΩ • $\pm 1\%$ • 4-terminal • Aluminum-housed chassis mount
		SPR-859	1 size	0.625 and 0.75 [15.9 and 19]	2	<ul style="list-style-type: none"> • 0.003 Ω to 0.05 Ω • $\pm 1\%$ min. • 4-terminal molded





SHUNTS, CURRENT SHUNTS, AND CURRENT-SENSING RESISTORS

Resistive Products

Current Sensors, Lower-Ohm: Radial Leads

These current sensors with radial leads are examples of the range of capabilities available. Radial-leaded current sensors take up less board space for a given size.

Brands	Product Image	Part Number	Sizes Available	Length (inch / [mm])	Power Rating (W)	Resistance Range, Tolerance, and Other Features
Vishay Dale		SPR-1012	1 size	1.03 [26]	4	<ul style="list-style-type: none"> • 0.01 Ω / 0.1 Ω, 10 to 1 ratio divider • $\pm 1\%$ • 5-terminal coated
Vishay Sfernice		RTO	2 sizes	0.59 [15]	20 and 50	<ul style="list-style-type: none"> • 0.046 Ω to 1 MΩ • $\pm 1\%$ • TO220 package • Heat sink mounting

Current Sensors, Lower-Ohm: Axial/Radial Leads

Axial/radial lead configurations have the advantage of short potential connection leads to the PC board thus minimizing thermal EMF generation.

Brands	Product Image	Part Number	Sizes Available	Length (inch / [mm])	Power Rating (W)	Resistance Range, Tolerance, and Other Features
Vishay Dale		SPR-779	1 size	0.675 [17]	1	<ul style="list-style-type: none"> • 0.01 Ω to 0.025 Ω • $\pm 1\%$ • 4-terminal molded



Characteristics and Design Considerations

Figure 1. The Equivalent Circuit

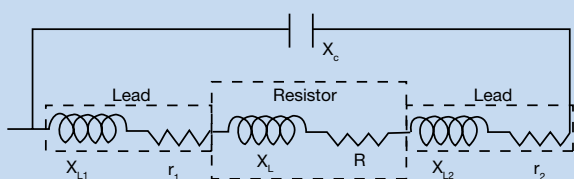
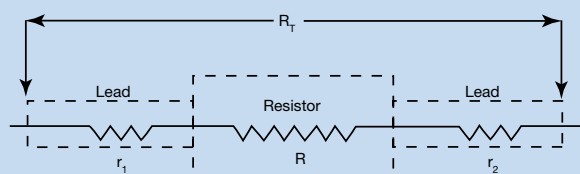

Figure 2. The Simplified Circuit



lead connections become large inaccuracies in readings. Furthermore, since the lead material is likely to be copper (with a resistance change with temperature (TCR) of +3900 ppm/°C) and the shunt might be manganin (with a TCR of -20 ppm/°C), then Δr is very large compared to ΔR and the device is useless in a temperature-variable application.

In the 19th century, Lord Kelvin developed, among other things, the four-terminal method of measurement, which eliminated both the uncertainty of lead resistance and lead response to temperature. Figure 3 is the Kelvin solution. If the voltage measuring system used here is of a high impedance, then r_5 approaches infinity and the measurement current I_m approaches zero. With zero I_m there is zero IR drop through r_3 and r_4 , and therefore it does not matter whether the contact resistance is large or small. It also does not matter if the contacts have a high TCR. Similarly, the TCR of the current leads is no longer important because the voltage connections are fixed inside the lead resistance, and, the resistance and TCR of the element only are sensed. Any errors associated with the lead resistance, contact resistance, and/or lead TCR are thus eliminated. **A Kelvin connection to a four-terminal resistor is essential for precise current sensing.**

Tolerance and Measurement of Resistance at Low Values

The ability to measure low values to tight tolerances is a concern to both the manufacturer and the user. In many cases, coordination of reading ability by exchange of serialized units with recorded readings becomes necessary. The problem is compounded in the cases of high-current shunts where the self-heating will cause the “in-service” resistance value to be different than that obtained with low-current-level measuring equipment. Therefore, the measurement conditions must be defined (agreed upon) at the time of specification preparation, i.e., resistance value as determined by specified current and measured IR drop following a period of stabilization.

Kelvin Connection

A Kelvin or four-terminal connection is required in these low-ohmic-value products to measure a precise voltage drop across the resistive element. In these applications, the contact resistance and the lead resistance may be greater than that of the element resistance itself, so lead connection errors and lead temperature coefficient of resistance errors can be significant if only a two-terminal connection is employed. Figure 1 shows a resistor in series with an inductor in parallel with a capacitor including the resistance and inductance of the leads. This is the equivalent circuit of a two-terminal resistor.

Ignoring the inductance and capacitance for now, the two-terminal resistor is shown in Figure 2. If $r_1 = r_2 = r$, then the total resistance $R_T = R + 2r$. The lead resistance r is uncertain because there is no user-assured connection to the lead. Thus, if we allow r to be significant compared to R , small inaccuracies in

Figure 3. Kelvin Connection

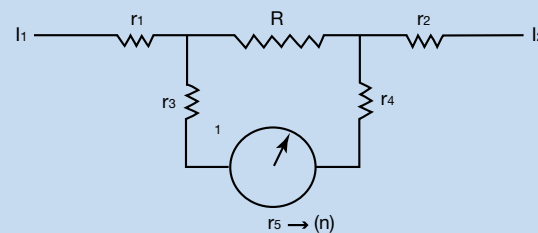



Measurement equipment is available from a number of sources with varying stated accuracies. Digital multimeters with from 5½ to 8½ digits may have a 1 Ω full-scale range. If the stated accuracy is sufficient, these devices are suitable for direct reading of resistance down to 0.001 Ω when equipped with Kelvin connections. If indirect readings (calculated from current and voltage readings) are acceptable, then the digital multimeter can be switched from the ohms to the voltage function, and with a constant-current power supply across the known and unknown resistors in series. IR drops across the potential leads can be measured and compared. This method permits measurement at rated current which is not available with the “ohms” function of multimeters and/or most low-ohm bridges. Thus, measurement with the higher rated current assures correct results at anticipated operating conditions. One useful variation of this scheme is to read many resistors at one time by passing the constant current through all resistors in series and switching the voltage probes from one resistor to the next. Large quantities are thus measured quickly. It should be noted that manufacturers will generally prefer a resistance specified at room temperature and not have to deal with the stabilization time necessary for rated current readings. If rated current readings are required, a test charge may be imposed.

Power Rating and Thermal Dissipation

Resistors are energy convertors converting electrical energy to thermal energy in accordance with the formula $P = EI$ where the power consumed P watts is the result of impressing E volts across the resistor and producing I current. Also from Ohm’s law, these additional formulas are recalled here for convenience: $P = I^2 R$, $P = E^2/R$, and one watt-hour is worth 3.413 BTUs. The energy converted by the resistor cannot be allowed to continually build up and be stored as heat within the resistor. Eventually it must be passed to another medium for disposal. Equilibrium is eventually reached such that the heat generation within the resistor is equal to the heat disposal to the other medium and a stable internal temperature results. This temperature must not exceed a tolerable limit since further increase will alter the integrity of the resistor or even destroy it. Since this temperature limit is within the resistor, it is referred to as the “maximum internal hot spot temperature” as if there were one spot within the device that is most likely to overheat.

The internal hot-spot temperature must be limited to that which will not cause a permanent performance change through metallurgical degradation in a metal alloy resistive element or a chemical change in a cermet or other non-metallic element. More often than not, however, it is limited to the lower temperatures that will be tolerated by any coatings in contact with the element.

From the internal hot spot the heat flows through the body of the resistor and (in the absence of a heat sink) passes to the other medium by radiation and convection from the resistor body. With a heat sink, more rapid removal by conduction takes place. In the case of axial-leaded cap and core resistors, the leads act as thermal conductors to the board traces (which act as heat sinks) and dissipate a major amount of the total heat from the resistor.

The equilibrium temperature will be reached most rapidly with the resistor in still air. Additional power can be dissipated before reaching the maximum temperature if there is circulation of the air. A heat sink, or an oil bath, or cooling water circulation becomes necessary to remain below the maximum internal hot spot temperature when dissipating increasingly large amount of power.

The resistor manufacturer has determined the maximum power in still air and/or with a specified heat sink that will limit the resistor internal hot spot temperature to a satisfactory level. This is the rated power and must not be exceeded. A separate power rating for still air and for a specified heat sink may be provided. Also, the other medium may not always be at room temperature, and therefore less power can be dissipated if the other medium is at an elevated temperature. A derating curve may be provided allowing use of the resistor in an elevated temperature environment without exceeding the maximum internal hot-spot temperature. These curves generally derate to zero power at some elevated temperature which is for these purposes “the maximum hot spot temperature.”

While manufacturers’ power ratings are serious specifications, they cannot be expected to exactly apply in every case. The thermal dissipation in critical applications may require further analysis. To limit the amount of calculation required, the temperature drop from the “internal hot spot” to some “test spot” on the body of the resistor is frequently known and available. The thermal analysis is thereby limited to factors associated with the other medium and confirmed by surface pyrometer readings on the “test spot.” This “test spot” with its “maximum external hot spot temperature” is frequently identified for simplicity as the “hot spot.”



One Short Pulse

The theory of pulse handling depends upon the pulse width. A short pulse of 100 milliseconds or less is assumed to never have time enough to do more than heat the element. Therefore, the calculation is based on the total mass of the element (wire) only being heated to the maximum internal hot-spot temperature. Example: A resistor element consisting of 10 grams of wire with a specific heat of 0.1 heated from 25 °C to a maximum internal hot spot temperature of 275 °C requires:

$$\frac{10 \times 0.1}{860} (275 - 25) = 0.29 \text{ watt-hours of equivalent}$$

Note: A calorie is 1/860 watt-hours.

If the pulse width is 10 milliseconds, the pulse power could be:

$$\frac{0.29 \times 3600 \times 1000}{10} = 104,400 \text{ watts max.}$$

Equally Spaced Repetitive Pulses

Here, the average power, which is the peak power multiplied by the pulse width divided by the cycle width, establishes a threshold temperature rise. Above this threshold to the maximum internal hot-spot temperature is additional pulse capacity. In reducing this theory to practice, assignment is given to the percentage of rated power that both the average and pulse power represent. As long as the sum of the two does not exceed 100 % of the rating, the application is satisfied.

Example: The pulse power is $P = V^2/R$ and the average power is $P_A = Pt/T$ where t is the pulse width and T is the cycle width. Calculate the average power and the % of rated power for the candidate resistor. Now using the derating curve, establish the threshold temperature that results and use it in the pulse calculation above. Calculate the pulse power that can be tolerated in the wire being heated above the new threshold temperature to the internal hot-spot temperature. This is the maximum pulse power allowed at this average power level.

Long Pulses (100 milliseconds to 5 seconds)

Here, the pulse heat generated is no longer retained fully within the wire, but some passes to other body members of the resistor. A short-time overload rating is frequently given, and this can be safely used as the long pulse rating. A factor of 5 times rated power is generally satisfactory for 5 seconds.

Allowable pulse power levels for pulses from 1 second to 25 seconds long can be found by 25 times rated power divided by the pulse time in seconds. Below 1 second, use the 1-second rating. Above 25 seconds, use rated power.

Current Rating

Some devices in this range of products are “current-limited” rather than power-limited. This comes from the fact that as electron flow is increased by increasing the voltage, there comes a point where the current no longer follows Ohm’s law. This “critical current density” varies for different resistance materials, but it must be kept in mind that leads and attachment hardware also have a critical current density. A current density up to 260 KA/in² may be tolerated by a particular metal, but the manufacturer’s rating is likely to be considerably below this limit for safety reasons.

Appropriately sized connecting wire must be used and the ratings of the wire manufacturer must be followed. Where a resistor current limit is specified, it must not be exceeded. Under certain circumstances, pulses of current in excess of the current limit can be tolerated. Please contact “Technical Support” by going to www.vishay.com and selecting “Contacts.”



SHUNTS, CURRENT SHUNTS, AND CURRENT-SENSING RESISTORS

Resistive Products

Reactance and Impedance

Reactance is the component of an AC impedance that defines a phase shift between the current and the voltage.

Impedance is the ratio of effective voltage over effective current in an AC circuit.

Reactance may be inductive or capacitive. In low-value resistors (below 10 Ω), the inductive reactance usually outweighs the capacitive reactance while higher values are more likely to be capacitive with bifilar or Ayrton-Perry winding. Pi, bifilar, and Ayrton-Perry winding are used to improve reactance.

Figure 4 shows the various components of resistor response to an AC signal in vectorial notation. “R” is the DC resistance of the device and “X_L” and “X_C” are the inductive and capacitive reactances, respectively. Figure 5 shows the sum of X_L and X_C leaving an effective net reactance “X_T”. The impedance “Z” is the Pythagorean sum of “R” and “X_T”. The AC impedance is always greater than the DC resistance unless X_L is exactly equal to X_C.

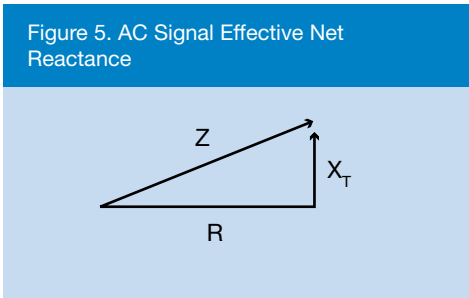
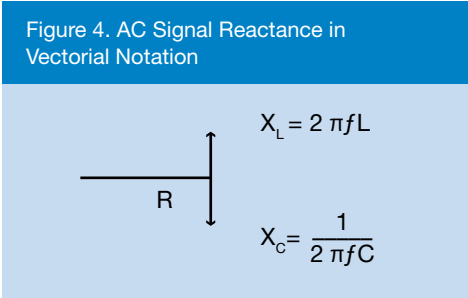

The products listed in this brochure are largely low-value resistors with little or no response to X_T until well up into the megahertz range. Therefore, the effect of reactance can largely be ignored referring only special requirements to Applications Engineering.

Thermal EMF

Dissimilar metals, in contact with each other, produce a small voltage. This voltage is variable with temperature and is therefore called a “thermal EMF” or thermocouple effect. The rate of change of voltage with temperature from an intermetallic junction is a function of the metallic combination. The sense of the voltage produced is either positive or negative, depending on which side of the combination is being considered the input. Virtually all resistors have intermetallic combinations, and it is presumed that they will eventually be connected to copper as a final intermetallic junction. Hence, copper is the typical reference metal. Table 1 is a brief synopsis of the thermal EMFs for various metals and alloys used in resistor construction vs. copper as the reference.

Thermal EMF is an important consideration in low-value resistors used in DC circuits. (It usually has no importance in AC circuitry). In particular, the importance in current sensors is obvious since the thermal EMF could be larger than the signal being discriminated.

Table 1. Thermal EMF of Selected Metals and Alloys	
Metal/Alloy	Thermal EMF vs. Copper μV/°C
Evanohm	+2.0
Cupron	-45.0
Manganin	-3.0
Zeranin	-1.3
Nickel	-22.0
Gold	+0.2
Silver	-0.2
Aluminum	-4.0



SHUNTS, CURRENT SHUNTS, AND CURRENT-SENSING RESISTORS

Resistive Products

Figure 6. No Thermal Difference End to End

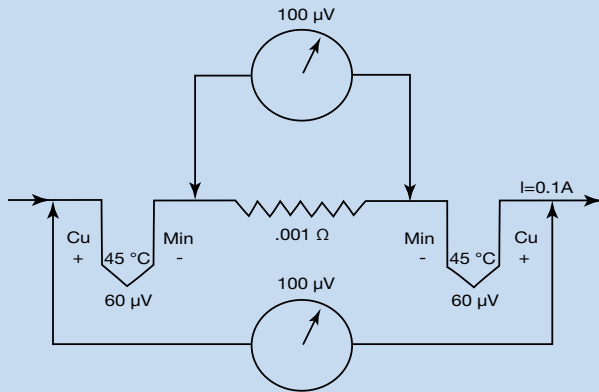

As noted earlier, thermal EMFs have polarity and so, for example, from copper to manganin and back to copper through a particular resistor, one end is a $+3 \mu\text{V}/^\circ\text{C}$ generator and the other end is a $-3 \mu\text{V}/^\circ\text{C}$ generator. In the ideal situation of both ends of the resistor being at the same temperature, the thermal EMFs are self-canceling. The manufacturer minimizes thermal EMF effects through the use of appropriate metals, but it is up to the user to see that the product is installed in such a way that the resistor is not being heated non-uniformly by other components. Figure 6 is the equivalent circuit when both ends of the resistor are at the same temperature. 7 is the equivalent circuit when one end is heated. Note that the $100 \mu\text{V}$ measured IR drop of Figure 6 became $130 \mu\text{V}$ apparent drop in Figure 7 when a temperature difference of 10°C is allowed to exist across the resistor.

Figure 7. 10° Thermal Difference End to End

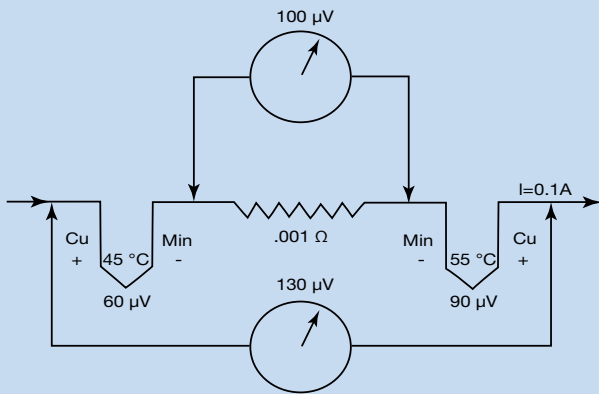

Noise

Noise is an unwanted AC signal from within the resistor. Two types of noise exist and can limit product usefulness under certain conditions.

Thermal noise, often called “Johnson noise,” is due to the random motion of electrons in the resistive material, which creates small fluctuating potential differences across the terminations.

Thermal noise is characterized by a continuous frequency spectrum. Its magnitude is independent of the material of the conductive element or its shape, and varies only with temperature and resistance.

Thermal noise can be obtained from the formula:

$$E^2 = 4KTR (f_2 - f_1)$$

where

K = Boltzmann's constant (1.38×10^{-23} joules/degree Kelvin)

T = Absolute temperature ($^\circ\text{C} + 273$)

R = Resistance of the conductor

E = Root mean square value of the thermal noise voltage

$(f_2 - f_1)$ = Bandwidth in hertz

The voltage developed by thermal agitation sets a limit on the smallest voltage that can be amplified without being lost in a background of noise.

Resistances composed of metal or metal alloys (wirewound, etc.) display the lowest combined noise level and can largely be ignored. However, resistances composed of conductive particles dispersed in an insulating matrix or films with imperfect lattice structure and non-conducting occlusions generate noise far in excess of the thermal agitation



SHUNTS, CURRENT SHUNTS, AND CURRENT-SENSING RESISTORS

Resistive Products

noise when a direct current is passed through the resistance. This type of noise arises from fluctuations in contact resistance between conducting sites within the matrix and is greater in higher values where the sites are fewer. It can also occur at poorly joined metal connections such as cold solder joints. The frequency spectrum of current noise is not continuous and appears in the lower audio frequency range. This may place a limitation on the use of thick film resistors under the circumstances of very small signal discrimination at mid frequencies.

The noise index is calculated from the formula:

$$Db = 20 \times \log_{10} = \frac{\text{Noise Voltage}}{\text{DC Voltage}} \text{ (over a 1-decade bandwidth)}$$

where noise voltage is the RMS current noise voltage generated by the resistor and the DC voltage is the voltage arising out of specified current flowing through the resistor at a specified temperature.

The index is usually expressed either as $\mu\text{V/V}$ or in decibels of the ratio of voltages. These are interchangeable as shown in Table 2.

Table 2. Noise Conversion

Db	$\mu\text{V/V}$
15	5.60
10	3.20
5	1.80
0	1.00
-5	0.56
-10	0.32
-15	0.18
-20	0.10
-25	0.056
-30	0.032
-35	0.018

Temperature Coefficient of Resistance (TCR)

Change in resistance as a function of temperature exists in all resistors to various extents. This change is seldom linear, but for convenience it is usually expressed as a straight line function. Sometimes the change is sought between two specific temperatures. Hence, the general equation for the instantaneous TCR at any temperature is:

$$\text{TCR}_{\text{inst}} = \frac{dR}{Rdt}$$

and the more useful TCR calculated from the chord slope from one temperature to another is:

$$\text{TCR}_{\text{chord}} = \frac{R2 - R1}{R1 (T2 - T1)}$$

Also, TCR is usually referred to room temperature (25 °C) as the reference temperature T1, and the second temperature T2 is either 0 °C or +60 °C for end use in instrumentation and -55 °C or +125 °C for military end use (power resistors to +275 °C). Note that TCR can be either positive or negative. By convention, an increase in resistance with an increase in temperature is a positive TCR. Also, note that self-heating causes a resistance change due to TCR. Table 3 gives the TCR for some resistance materials used in the range of products in this brochure.

Table 3. TCR, ppm/°C of Various Resistor Element Materials

Temperature Range	-55 °C to +25 °C	0 °C to +25 °C	+25 °C to +60 °C	+25 °C to +125 °C
Manganin	+50	+10	-5	-80
Zeranin	+20	± 2.5	± 5.0	+10
Evanohm	+5.0	+2.5	-2.5	-5.0
Foil	-1.0	-0.3	+0.3	+1.0
Thin Film	-10	-5.0	+5.0	+10
Thick Film	-100	-25	+50	+100



Design Factors

To help customers select the correct components for their application or design new components for specific applications, many design factors must be taken into consideration. Below are the minimum design factors needed before accurate component selection or design can be made.

You can obtain more information by sending a request to ww2bresistors@vishay.com or by contacting your local Vishay sales representative.

Shunts

- 1.0 Power rating required – how much power will be dissipated?
- 2.0 Disposal of heat generated – what services are available to remove heat? What services are available to remove forced air?
- 3.0 Mounting surface and hardware – what shock and vibration conditions dictate standard or special mounting?
- 4.0 Resistance value and tolerance – the tolerance must be consistent with the ability to measure. With specific electrical gage points identified, two-terminal devices can be toleranced to discriminate 0.001 Ω . Four-terminal devices can be toleranced to discriminate down to 0.0001 Ω . Thus, a two-terminal resistor of 0.1 Ω can be given a tolerance no tighter than $\pm 1.0\%$ (1.0% of 0.1 $\Omega = 0.001\ \Omega$) while a four-terminal resistor can be given a tolerance as tight as $\pm 0.1\%$ (0.1% of 0.1 $\Omega = 0.0001\ \Omega$).

Sensors

- 1.0 Current Rating – how much current is the sensor expected to handle? Continuously? Pulsed? Distortion-restricted?
- 2.0 Sensitivity – how much output signal is required per unit of current? (How much μV or mV per ampere?)
This sets the resistance value and the power rating.
- 3.0 Resistance Value – the required sensor resistance is equal to the current rating times the sensitivity divided by the current rating or numerical equivalence to the sensitivity, but in ohms.
Example: A 2-A sensor with 100 mV/A sensitivity will have a full scale output of 0.2 V
 $\Delta R = E \div I = 0.2 \div 2 = 0.1\ \Omega$
- 4.0 Power Rating – the required power rating may be greater than the product E_{max} and I_{max} if the sensitivity must be the same following self-heating. A positive TCR will cause the resistance value to increase along with the sensitivity. This effect can be minimized by over specifying the power rating or moving to a lower-TCR element.

Typical Applications

- DC/DC converters
- AC/DC converters
- Power supplies
- Motor controls
- Instrumentation
- Battery fuel gauges
- Li-Ion battery management
- VRMs in notebook computers
- Automotive applications
 - Electronic power steering
 - Body electronics
 - Engine control modules
 - ABS
 - Electric vehicles
- Household/industrial electric meters



SHUNTS, CURRENT SHUNTS, AND CURRENT-SENSING RESISTORS

Resistive Products

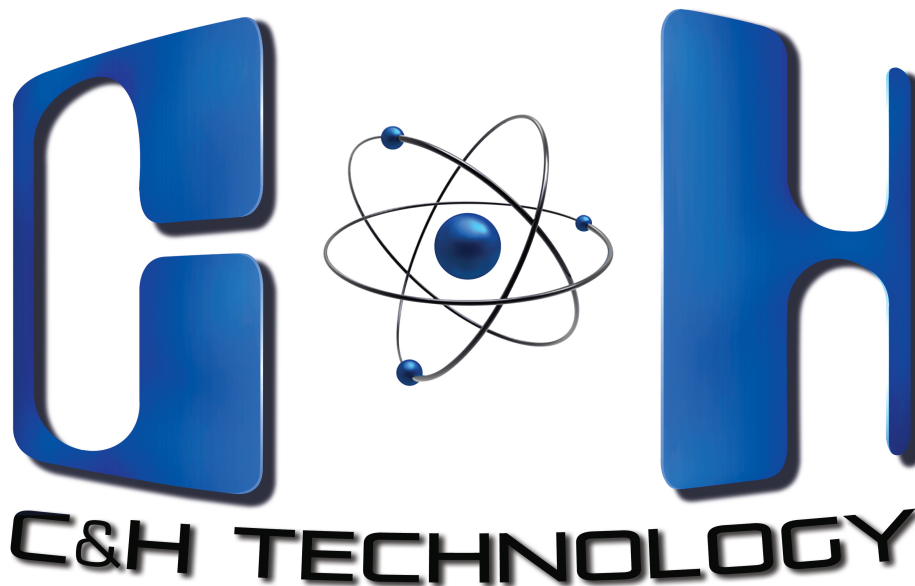

6121 Baker Rd.
Suite 108
Minnetonka, MN 55345

Phone: 800-274-4284
Fax: 952-933-6223
www.chtechnology.com

