



ALUMINUM ELECTROLYTIC CAPACITORS IN POWER APPLICATIONS

CAPACITORS

CAPABILITIES



SEMICONDUCTORS

RECTIFIERS

- Schottky (single, dual)
- Standard, Fast and Ultra-Fast Recovery (single, dual)
- Bridge
- Superrectifier®
- Sinterglass Avalanche Diodes

HIGH-POWER DIODES AND THYRISTORS

- High-Power Fast-Recovery Diodes
- Phase-Control Thyristors
- Fast Thyristors

SMALL-SIGNAL DIODES

- Schottky and Switching (single, dual)
- Tuner/Capacitance (single, dual)
- Bandswitching
- PIN

ZENER AND SUPPRESSOR DIODES

- Zener (single, dual)
- TVS (TRANSORB®, Automotive, ESD, Arrays)

FETs

- Low-Voltage TrenchFET® Power MOSFETs
- High-Voltage TrenchFET® Power MOSFETs
- High-Voltage Planar MOSFETs
- JFETs

OPTOELECTRONICS

- IR Emitters and Detectors, and IR Receiver Modules
- Optocouplers and Solid-State Relays
- Optical Sensors
- LEDs and 7-Segment Displays
- Infrared Data Transceiver Modules
- Custom Products

ICs

- Power ICs
- Analog Switches

MODULES

- Power Modules (contain power diodes, thyristors, MOSFETs, IGBTs)

PASSIVE COMPONENTS

RESISTIVE PRODUCTS

- Film Resistors
 - Metal Film Resistors
 - Thin Film Resistors
 - Thick Film Resistors
 - Metal Oxide Film Resistors
 - Carbon Film Resistors
- Wirewound Resistors
- Power Metal Strip® Resistors
- Chip Fuses
- Variable Resistors
 - Cermet Variable Resistors
 - Wirewound Variable Resistors
 - Conductive Plastic Variable Resistors
- Networks/Arrays
- Non-Linear Resistors
 - NTC Thermistors
 - PTC Thermistors
 - Varistors

MAGNETICS

- Inductors
- Transformers

CAPACITORS

- Tantalum Capacitors
 - Molded Chip Tantalum Capacitors
 - Coated Chip Tantalum Capacitors
 - Solid Through-Hole Tantalum Capacitors
 - Wet Tantalum Capacitors
- Ceramic Capacitors
 - Multilayer Chip Capacitors
 - Disc Capacitors
- Film Capacitors
- Power Capacitors
- Heavy-Current Capacitors
- Aluminum Capacitors

Aluminum Electrolytic Capacitors

Vishay BCcomponents B.V.

Marketing Dept.
P.O. Box 10076
NL-8000 GB Zwolle,
The Netherlands
Phone: +31 38 4575 305
Fax: +31 38 4575 464

www.vishay.com



ALUMINUM ELECTROLYTIC CAPACITORS

for Motor Drives

Introduction to the application

Motor drives are used to control the speed of various motors in all kinds of systems, from the small pumps and motors in household washing machines and central heating and air-conditioning systems to the large motors found in industrial machinery.

Selecting the best capacitor for your motor drive application

Aluminum capacitors are often used as DC link capacitors in motor drives, both in 1-phase and 3-phase designs.

The aluminum capacitor is used as an energy buffer to ensure stable operation of the switch mode inverter driving the motor. The aluminum capacitor also functions as a filter to prevent high-frequency components from the switch mode inverter from polluting the mains voltage.

The key selection criterion for the aluminum capacitor is the required ripple current. The ripple current consists of two components, a low-frequency ripple (50 Hz to 200 Hz) from the input and a high-frequency component from the inverter, typically 8 kHz to 20 kHz.

To maximize its operating life, the aluminum capacitor should be located on the coolest possible area of the PCB. Forced cooling or mounting of the capacitor on a heat sink may increase device lifetime by as much as fourfold, especially in combination with the extended cathode construction inside the aluminum capacitor.

It is advisable to specify a minimum capacitance to ensure stable operation of the drive. The capacitor's inductance (ESL) may contribute to the occurrence of transient signals. ESL values below 13 nH can be reached in large case size screw terminal devices.

Series and parallel connections are common techniques used to allow aluminum capacitors to operate at voltages up to 1200 V. Care should be taken to balance the intermediate voltage between the capacitors.

Our focus series

For PCB mounting we offer 2-pin, 3-pin, or 4-pin snap-in capacitors with long life and high current ratings, some with an internal extended cathode design, enabling fast transfer of heat outside of the capacitor body. For larger industrial applications, large can screw terminal aluminum capacitors are available, all with extended cathode construction.



Main series for PCB mounting	Main series for high-power industrial drives
159 PUL-SI (Standard, 105 °C)	102 PHR-ST (Long life, high ripple current, 85 °C)
193 PUR-SI (Low ESR, high ripple current, 105 °C)	104 PHL-ST (High ripple current, 105 °C)
198 PHR-SI (High ripple current, extreme long life, 85 °C)	
096 PLL-4TSI (4-Terminal, 85 °C)	

2 examples of the 198 PHR-SI series:

ELECTRICAL DATA AND ORDERING INFORMATION											
U _R (V)	C _R 100 Hz (μF)	NOMINAL CASE SIZE Ø D x L (mm)	I _R 100 Hz 85 °C (A)	I _{L1} 1 min (mA)	I _{L5} 5 min (mA)	TYP. ESR 100 Hz (mΩ)	MAX ESR 100 Hz (mΩ)	TYP. Z 10 kHz (mΩ)	MAX. Z 10 kHz (mΩ)	ORDERING CODE MAL2198...	
										2-TERM.	3-TERM.
400	470	35 x 45	2.72	1132	380	129	203	80	153	36471E3	16471E3
450	560	35 x 60	3.10	1516	508	100	171	60	120	57561E3	77561E3

3 examples of the 102 PHR-ST series:

ELECTRICAL DATA AND ORDERING INFORMATION FOR 102 SERIES											
U _R (V)	C _R 100 Hz (μF)	NOMINAL CASE SIZE Ø D x L (mm)	I _R 100 Hz 85°C (A)	I _{L5} 5 min (mA)	ESR max. 100 Hz (mΩ)	Z max. 20 kHz (mΩ)	HIGH POST M5 DISC		HIGH CURRENT M6 DISC		
							ST ORDERING CODE MAL2102...	ST BOLT NUT ORDERING CODE MAL2102...	ST ORDERING CODE MAL2102...	ST BOLT NUT ORDERING CODE MAL2102...	
							250	4700	76 x 105	15.3	2.35
400	3300	76 x 105	13.4	2.64	40	27	26332E3	66332E3	46332E3	86332E3	
450	5600	76 x 146	17.3	5.04	23	15	17562E3	57562E3	37562E3	77562E3	

Figure 1: a typical block diagram of the motor drive

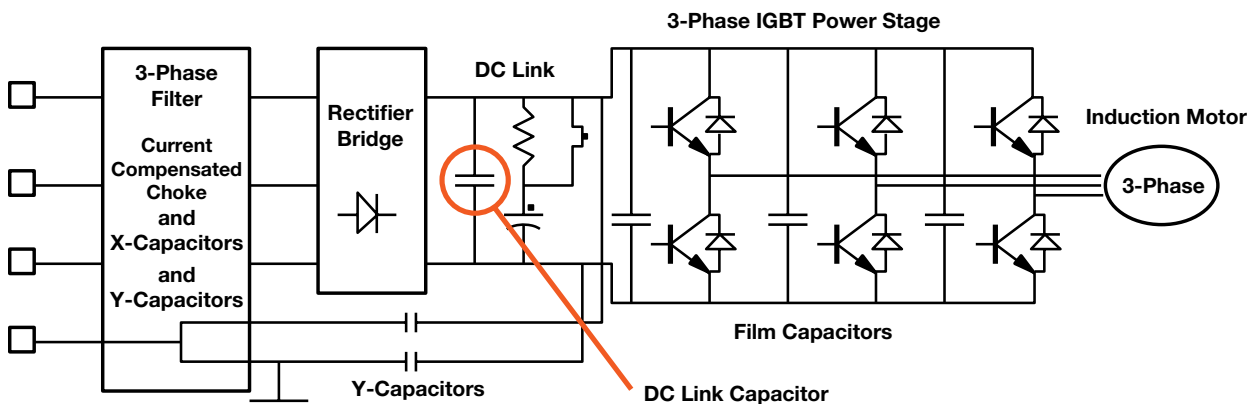



ALUMINUM ELECTROLYTIC CAPACITORS

for Solar Inverters

Introduction to the application

Solar photovoltaic applications have shown strong growth globally since 2005. Solar inverters are used to efficiently convert the DC power generated by the solar panels into useable AC power for the electricity grid or household systems. Solar inverters are available with a wide range of power ratings. Depending on the power range of the total system, single-household inverters range up to 3 kW, coupled string inverters up to 10 kW, and large central inverters up to 500 kW.



Selecting the best capacitor for your solar inverter

Power capacitors are used in solar inverters as DC-link capacitors, creating enough DC energy to enable smooth operation of the DC/AC converter. Depending on the power range, maximum allowable voltage, available space, lifetime requirements, and cost of design, either aluminum or power film capacitors may be used. Both types are available from Vishay.

The right aluminum capacitor for the job depends on two main operating conditions:

Normal operation: In this condition, the Maximum Power Point (MPP) tracking system will maintain a reduced voltage on the capacitors in combination with rather high ripple currents and elevated temperatures inside the inverter housing. Capacitor lifetime is mainly determined by the applied ripple current and ambient temperature in normal operation mode.

Off-line operation: In this mode, the solar system is disconnected from the grid, and the voltage on the capacitor rises to the maximum output voltage of the solar cells. Under this condition, there is no ripple current applied on the capacitor and the ambient temperature in the inverter housing is reduced. This operation mode determines the maximum voltage the capacitor is designed for under no-load or low-load conditions at moderate temperatures inside the housing.

Typical maximum output voltages for solar panels are 600 V, 800 V, and 1000 V. A pair of aluminum capacitors connected in series is needed to cover this voltage range. Care should be taken to balance the voltage over the series connection of the aluminum capacitors. Balancing the voltage on the center point between the two series capacitors is vital, but could cause significant efficiency losses caused by using e.g. balancing resistors.

Further important parameters for the aluminum capacitor include the total capacitance, which should be high enough to maintain smooth operation of the converter.

Our focus series

For PCB mounting Vishay offers 2-, 3-, and 4-terminal snap-in products in case sizes ranging from 30 mm x 40 mm to 45 mm x 100 mm. For central inverters we offer screw terminal series in case sizes up to 90 mm x 220 mm.

Aluminum Electrolytic Capacitors for Solar Inverters

Design examples for solar applications:

Series	Cap (μF)	Size D*H (mm)	U _R (V)	U _C (V)	I _R (100 Hz) (A)	Lifetime (U _R , 85 °C)	Lifetime (U _C , I _R , 105 °C)
193 PUR-SI	330	30 x 50	500	400	2.3	2 000 hrs	10 000 hrs
157 PUM-SI	680	35 x 60	500	420	3.2	1 000 hrs	7 000 hrs
095 PLL-4TSI	1000	45 x 70	500	450	3.8	5 000 hrs	5 000 hrs
159 PUL-SI	1200	35 x 80	320	-	5.1	-	7 000 hrs
104 PHL-ST	4700	76 x 175	500	450	12.1	20 000 hrs	10 000 hrs

Figure 2: a typical block diagram of a solar inverter

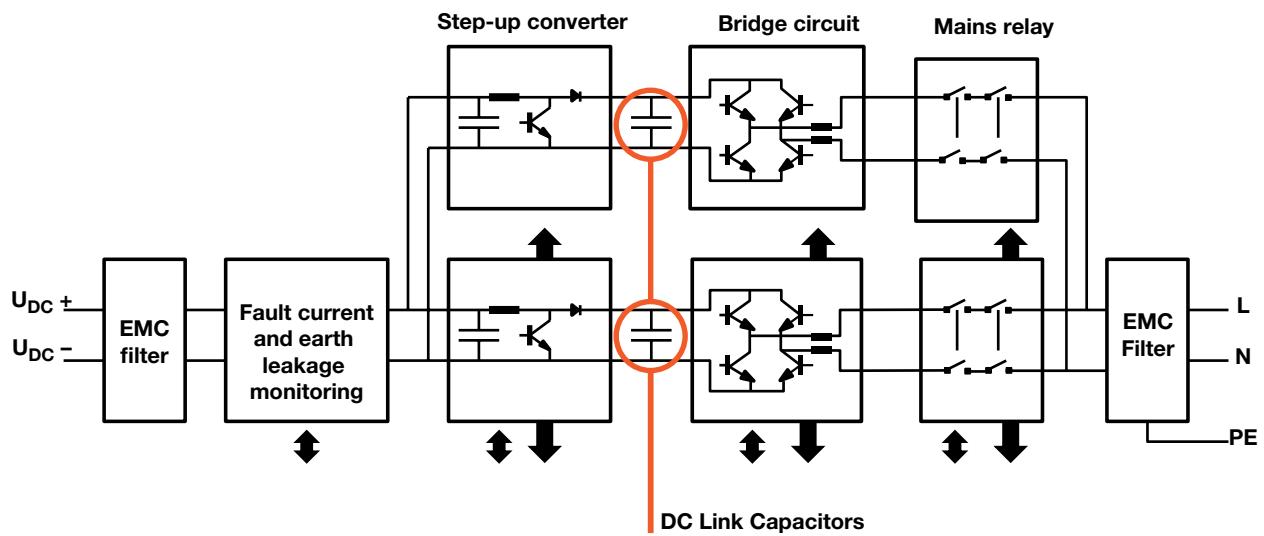



ALUMINUM ELECTROLYTIC CAPACITORS

for Traction Applications

Introduction to the application

Traction is a blanket term for applications in trains or “rolling stock.” Both the electrical propulsion systems as well as the electrical systems supporting the brakes, lighting, power supply are focus area included in this application category.

Selecting the best capacitor for your traction application

Aluminum electrolytic capacitors are used in two main applications in traction:

- As DC link capacitors in traction drives used to control the speed of large electrical motors in rolling stock
- As DC link capacitors in auxiliary power supplies in rolling stock



In both fields the aluminum capacitor is used as an energy buffer to ensure stable operation of the switch mode inverter driving the motor or auxiliary power circuit. The aluminum capacitor also functions as a filter to prevent high-frequency components in the switch mode alternator from disturbing the mains input.

The key selection criterion for the aluminum capacitor is the needed ripple current, which corresponds to the 8 kHz to 20 kHz high-frequency ripple currents generated by the inverter.

To maximize its operating life, the aluminum capacitor should be located on the coolest possible area of the PCB. Forced cooling or mounting of the cap on a heat sink may increase component lifetime, especially in combination with the extended cathode construction inside the aluminum capacitor.

It is advisable to specify a minimum capacitance to ensure stable operation of the drive. The capacitor’s inductance (ESL) may contribute to the occurrence of transient signals. ESL values below 13 nH can be reached in large case size screw terminal devices.

Both series and parallel connections are commonly used with aluminum capacitors as the voltages in rolling stock may well reach up to 1200 V. In such cases three aluminum capacitors can be used in series. Care should be taken to balance the intermediate voltage between the capacitors.

For higher voltage ranges and heavy duty applications, power film resistors, also available from Vishay, are the best option.

Our focus series

For traction we offer large can screw terminal aluminum capacitors including models with an extended cathode construction for optimized cooling.

Main series for high-power industrial drives
102 PHR-ST (Long life, high ripple current, 85 °C)
104 PHL-ST (High ripple current, 105 °C)

Two examples of the 102 PHR-ST series:

ELECTRICAL DATA AND ORDERING INFORMATION FOR 102 SERIES; 85 °C - 10 000 hrs											
U _R (V)	C _R 100 Hz (μF)	NOMINAL CASE SIZE Ø D x L (mm)	I _R 100 Hz 85 °C (A)	I _{L5} 5 min (mA)	ESR max. 100 Hz (mΩ)	Z max. 20 kHz (mΩ)	HIGH POST M5 DISC		HIGH CURRENT M6 DISC		
							ST ORDERING CODE MAL2102...	ST BOLT NUT ORDERING CODE MAL2102...	ST ORDERING CODE MAL2102...	ST BOLT NUT ORDERING CODE MAL2102...	
350	15 000	90 x 220	31.2	10.5	10	8	-	-	45153E3	85153E3	
400	10 000	76 x 220	22.1	8.0	14	11	16103E3	56103E3	36103E3	76103E3	

Two examples of the 104 PHL-ST series:

ELECTRICAL DATA AND ORDERING INFORMATION FOR 104 SERIES; 105 °C - 5 000 hrs											
U _R (V)	C _R 100 Hz (μF)	NOMINAL CASE SIZE Ø D x L (mm)	I _R 100 Hz 85 °C (A)	I _{L5} 5 min (mA)	ESR max. 100 Hz (mΩ)	Z max. 20 kHz (mΩ)	HIGH POST M5 DISC		HIGH CURRENT M6 DISC		
							ST ORDERING CODE MAL2104...	ST BOLT NUT ORDERING CODE MAL2104...	ST ORDERING CODE MAL2104...	ST BOLT NUT ORDERING CODE MAL2104...	
350	15 000	90 x 220	25.6	10.5	13	12	-	-	45153E3	85153E3	
400	10 000	90 x 220	22.1	8.0	17	14	-	-	46103E3	86103E3	

Figure 3: a typical block diagram of the application

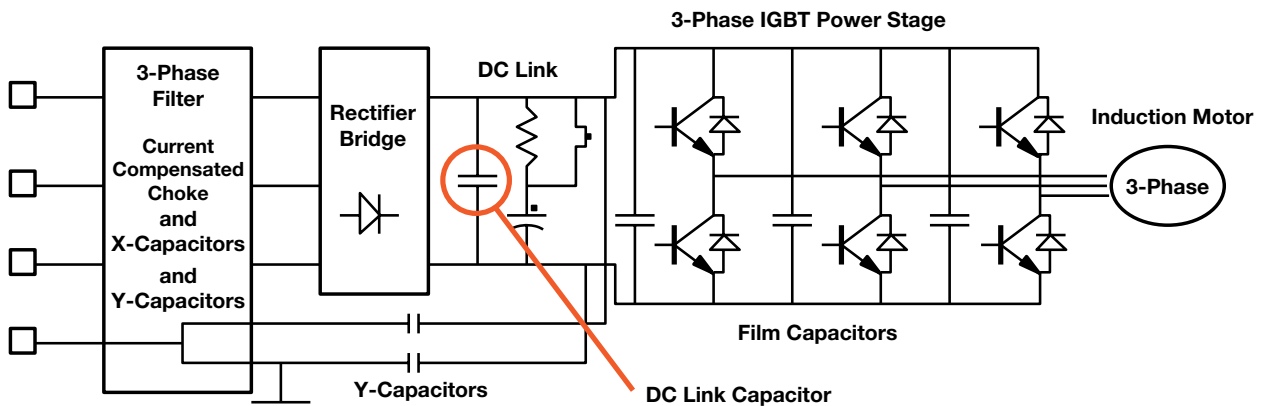



ALUMINUM ELECTROLYTIC CAPACITORS

for Uninterruptible Power Supply (UPS) Applications

Introduction to the application

Uninterruptible power supplies (UPS) are used to maintain power during short power outages. UPS are available in off-line and on-line types, and also offer varying power levels and maximum operating times for interruption coverage.

Selecting the best capacitor for your UPS

Aluminum capacitors are often used as DC-link capacitors in UPS, both in on-line as well in off-line systems. The aluminum capacitor is used as an energy buffer to ensure stable operation of the output DC/AC converter of the UPS system. The aluminum capacitor also functions as a filter to prevent high-frequency components in the switch mode alternator from disturbing the mains input.

The key selection criterion for the aluminum capacitor is the needed ripple current. The ripple current consists of two components, a low-frequency ripple (50 Hz to 200 Hz) from the input and a high-frequency component from the DC/AC converter, typically 10 kHz to 40 kHz.

To maximize its operating life, the aluminum capacitor should be located on the coolest possible area of the PCB. Forced air-cooling will reduce the overall temperature of the capacitor, enabling larger ripple current capabilities or longer life. It is advisable to specify a minimum capacitance to ensure stable operation of the drive.

Series and parallel connections are used as common techniques to allow aluminum capacitors to operate at voltages up to 1200 V. Care should be taken to balance the intermediate voltage between the series connected capacitors, without reducing the efficiency of the UPS system significantly.

Our focus series

For PCB mounting we offer 2-pin, 3-pin or 4-pin snap-in capacitors with long life and high current ratings, all with internal extended cathode design, enabling fast transfer of heat outside of the capacitor body. For larger industrial applications, large can screw terminal aluminum capacitors, including the extended cathode construction are available.



Main series for PCB mounting	Main series for high-power industrial drives
159 PUL-SI (Standard, 105 °C)	102 PHR-ST (Long life, high ripple current, 85 °C)
193 PUR-SI (Low ESR, high ripple current, 105 °C)	104 PHL-ST (High ripple current, 105 °C)
198 PHR-SI (High ripple current, extreme long life, 85 °C)	
096 PLL-4TSI (4-Terminal, 85 °C)	

Two examples of the 198 PHR-SI series:

ELECTRICAL DATA AND ORDERING INFORMATION											
U _R (V)	C _R 100 Hz (μF)	NOMINAL CASE SIZE Ø D x L (mm)	I _R 100 Hz 85 °C (A)	I _{L1} 1 min (mA)	I _{L5} 5 min (mA)	TYP. ESR 100 Hz (mΩ)	MAX ESR 100 Hz (mΩ)	TYP. Z 10 kHz (mΩ)	MAX. Z 10 kHz (mΩ)	ORDERING CODE MAL2198...	
										2-TERM.	3-TERM.
400	470	35 x 45	2.72	1132	380	129	203	80	153	36471E3	16471E3
450	560	35 x 60	3.10	1516	508	100	171	60	120	57561E3	77561E3

Three examples of the 102 PHR-ST series:

ELECTRICAL DATA AND ORDERING INFORMATION FOR 102 SERIES										
U _R (V)	C _R 100 Hz (μF)	NOMINAL CASE SIZE Ø D x L (mm)	I _R 100 Hz 85°C (A)	I _{L5} 5 min (mA)	ESR max. 100 Hz (mΩ)	Z max. 20 kHz (mΩ)	HIGH POST M5 DISC		HIGH CURRENT M6 DISC	
							ST ORDERING CODE MAL2102...	ST BOLT NUT ORDERING CODE MAL2102...	ST ORDERING CODE MAL2102...	ST BOLT NUT ORDERING CODE MAL2102...
250	4700	76 x 105	15.3	2.35	29	19	23472E3	63472E3	43472E3	83472E3
400	3300	76 x 105	13.4	2.64	40	27	26332E3	66332E3	46332E3	86332E3
450	5600	76 x 146	17.3	5.04	23	15	17562E3	57562E3	37562E3	77562E3

Figure 4: a typical block diagram of an uninterruptible power supply

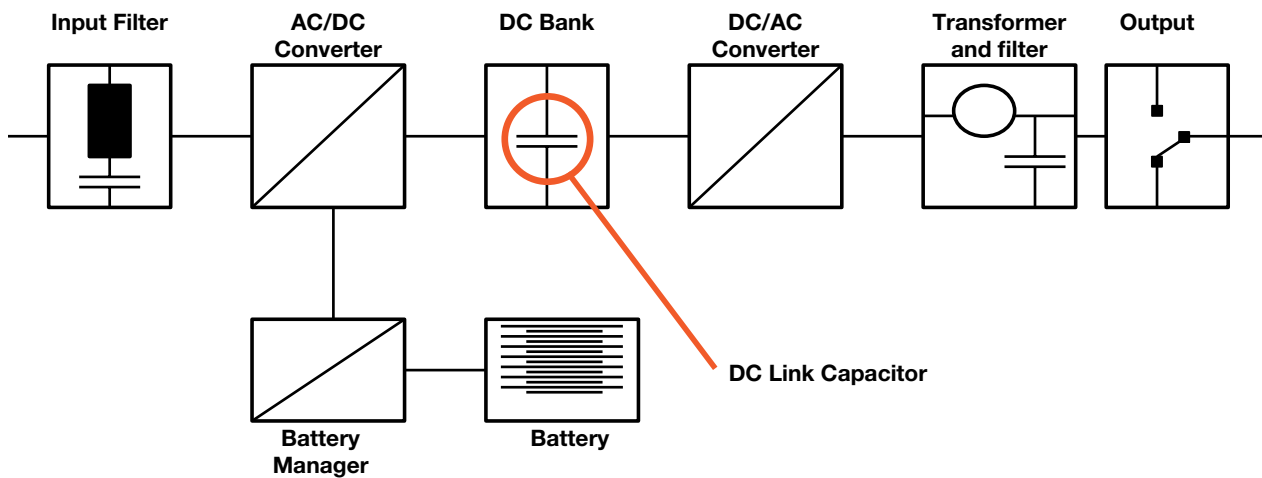



ALUMINUM ELECTROLYTIC CAPACITORS

for Pulsed Power Applications

Introduction to the application

Pulsed power applications are those in which the consumption of electrical energy takes the form of distinct pulses rather than having a continuous profile. Good examples of pulsed power applications are welding equipment, X-rays, and high-frequency plasma torches.



Selecting the best capacitor for your pulsed power application

Aluminum capacitors are often used as an energy buffer that is capable of generating an electrical energy boost to operate the primary function of the application.

The main parameter in this application is the minimum capacitance of the aluminum capacitor.

This capacitance defines the magnitude of the electrical energy boost the device can generate.

Of secondary importance is the inductance of the capacitor (ESL), for which large values may increase the occurrence of transient signals. Values of ESL below 13 nH for large case size screw terminals are available.

Care should be given to the voltage drop over the capacitors during the discharge cycle.

A full discharge would require design adaptations in the capacitor, whereas discharges in the range of 30 % to 40 % of the maximum operating voltage can prolong capacitor lifetime in the application significantly.

Our focus series

For PCB mounting, we offer 2-pin, 3-pin, or 4-pin snap-in capacitors with high specific capacitance, long life, and an internal extended cathode design. For high-voltage industrial applications such as professional welding, HF plasma torches, and X-ray equipment, we recommend our Large Can Screw Terminal Aluminum Capacitors, including the extended cathode construction.

Main series for PCB mounting	Main series for high-power industrial drives
157 PUM-SI (Standard, 85 °C)	102 PHR-ST (Long life, high ripple current, 85 °C)
159 PUL-SI (Standard, 105 °C)	500 PGP (High C/V, 85 °C)
193 PUR-SI (Low ESR, high ripple current, 105 °C)	
096 PLL-4TSI (4-Terminal, 85 °C)	

Design examples for pulsed power applications:

Series	Style	UR (V)	Cap (µF)	Size D*H (mm)	Useful life
157 PUM-SI	Snap-In	300	1 000	35 x 50	5 000 h at 85 °C
159 PUL-SI	Snap-In	450	560	35 x 60	5 000 h at 105 °C
102 PHR-ST	Screw Terminal	350	15 000	90 x 220	10 000 h at 85 °C
102 PHR-ST	Screw Terminal	400	10 000	76 x 220	10 000 h at 85 °C
500 PGP-ST	Screw Terminal	450	16 000	90 x 220	2 000 h at 85 °C

Figure 5: Block diagram of a typical pulsed power application

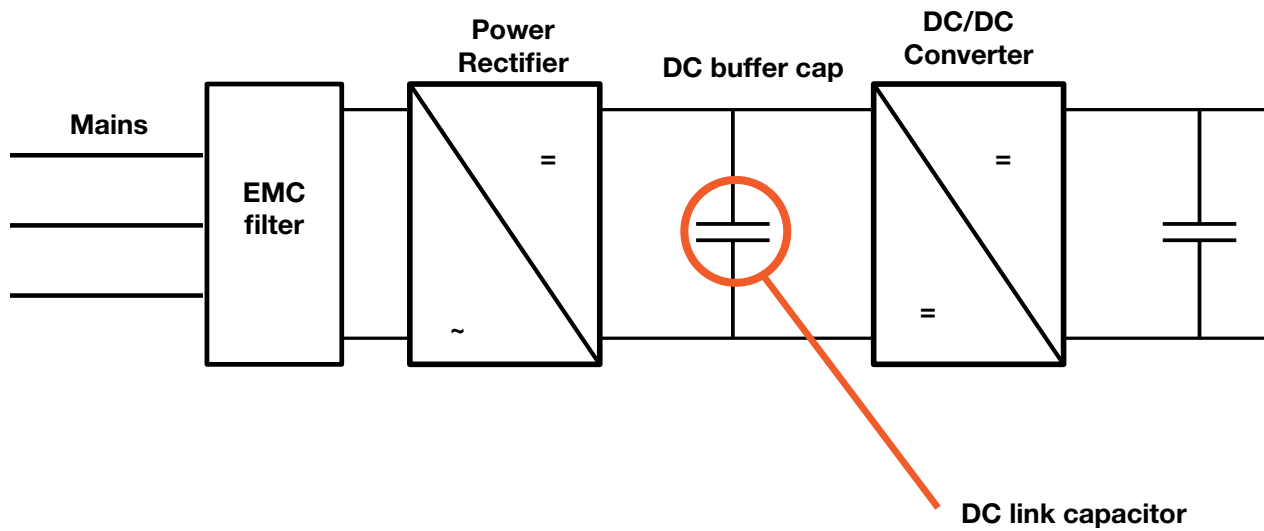

DISCLAIMER All product specifications and data are subject to change without notice. Vishay Intertechnology, Inc., its affiliates, agents, and employees, and all persons acting on its or their behalf (collectively, "Vishay"), disclaim any and all liability for any errors, inaccuracies or incompleteness contained herein or in any other disclosure relating to any product. Vishay disclaims any and all liability arising out of the use or application of any product described herein or of any information provided herein to the maximum extent permitted by law. The product specifications do not expand or otherwise modify Vishay's terms and conditions of purchase, including but not limited to the warranty expressed therein, which apply to these products. No license, express or implied, by estoppel or otherwise, to any intellectual property rights is granted by this document or by any conduct of Vishay. The products shown herein are not designed for use in medical, life-saving, or life-sustaining applications unless otherwise expressly indicated. Customers using or selling Vishay products not expressly indicated for use in such applications do so entirely at their own risk and agree to fully indemnify Vishay for any damages arising or resulting from such use or sale. Please contact authorized Vishay personnel to obtain written terms and conditions regarding products designed for such applications. Product names and markings noted herein may be trademarks of their respective owners.

SEMICONDUCTORS:

Rectifiers • High-Power Diodes and Thyristors • Small-Signal Diodes • Zener and Suppressor Diodes
• FETs • Optoelectronics • ICs • Modules

PASSIVE COMPONENTS:

Resistive Products • Magnetics • Capacitors



One of the World's Largest Manufacturers of
Discrete Semiconductors and Passive Components

WORLDWIDE SALES CONTACTS



6121 Baker Road,
Suite 108
Minnetonka, MN 55345
Phone (952) 933-6190
Fax (952) 933-6223
1-800-274-4284
www.chtechnology.com

Build **Vishay**
into your **Design**

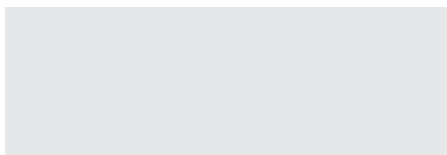

www.vishay.com